

2



MiCOM Px40 Series Multifunction Protection IEDs

AREVA T&D Automation announced further significant steps in the completion of its MiCOM Px40 series. The latest models incorporate an intuitive front panel HMI, for simple control of circuit breakers and switching devices, and for in/out selection of the user's own test and control features. LEDs are tri-state colored for annunciation, and high speed/high break relay contacts are rated for direct control duties. The range offering includes not only IEC 61850-8.1 station bus capability, but also interfacing via IEC 61850-9.2 to the process bus, including Non-Conventional Instrument Transformers (optical CTs). Such models are in service, at system voltages up to and including 800kV.

3

Toshiba distance protection with IEC 61850

The Toshiba GRZ100 distance protection meets the functional and performance requirements of the IEC 61850 standard implemented in a software environment and hardware architecture that will support future technological progress. The relay certified by KEMA in July 2006 demonstrated the high performance achieved for GOOSE messaging and is

the first of several Toshiba IEC 61850 products with transformer and line differential relays coming soon. Interoperability has been demonstrated at a number of events including several organised by the UCA International Users Group supported by multi-vendors in a virtual substation environment. The advanced numeric design of the relay features command protection

schemes using integral digital communication channels and programmable logic to reduce system costs and complexity. Other advanced techniques are included to enable, for example, tripping for faults that occur during power swing conditions.



4

Capacitor Bank Protection and Control System



GE Multilin's C70 Capacitor Bank Protection and Control System is based on the well-established and proven UR platform. Today, shunt capacitor banks play an increasingly vital role in blackout prevention and reactive support. Protecting this equipment has historically involved complex, custom protection schemes consisting of multiple products that rarely addressed the inherent system and bank unbalance. Now, there's a single universal product, called the C70 from GE Multilin, combining advanced bank protection with

automatic control for shunt capacitor applications. The current and voltage-based protection functions are designed to provide superior protection for grounded, ungrounded, tapped, single and parallel capacitor banks, supporting any capacitor bank configuration. The C70's balance protection elements provide unprecedented sensitivity due to unique auto-compensation implementations. The capacitor control function facilitates single and multiple implementations of volt, VAR, power factor and time of day control.

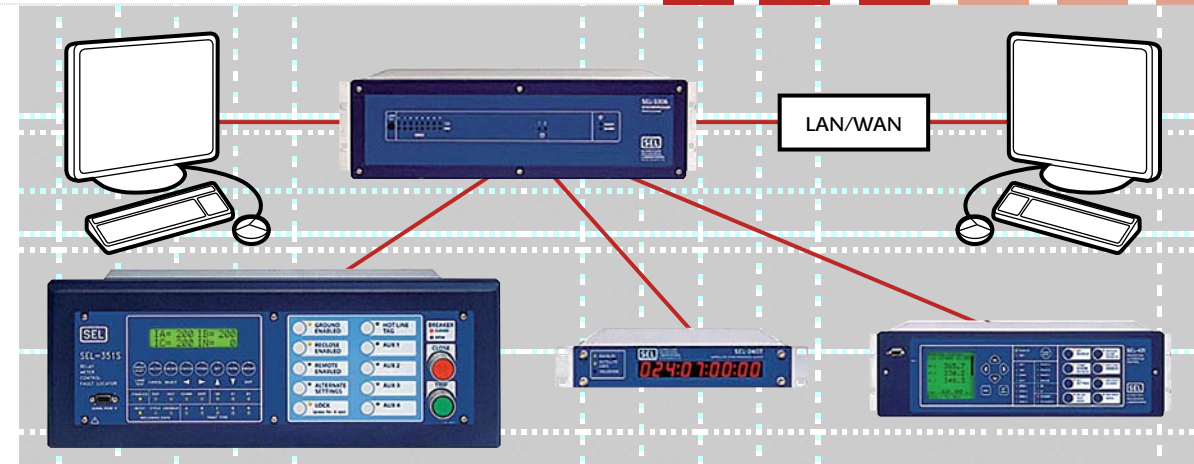

Phasor measurements now available in distribution relays

5

Schweitzer Engineering Laboratories, Inc. (SEL) announced that the SEL-351 family of distribution relays now includes built-in synchrophasor measurement technology. The synchrophasor capability in SEL-351 relays is also compatible with SEL synchroWAVE™ Software and the SEL-3306 Synchrophasor Processor. SEL-5077 synchroWAVE Server Software and the SEL-3306 time-correlate synchrophasor data from SEL-351 Relays and send the information to

display and archiving systems, such as SEL-5078 synchroWAVE Console Software. "Until recently, synchronized phasor measurements were available only from laboratory equipment or from expensive, stand-alone phasor measurement units," said SEL Founder and President Edmund O. Schweitzer. "The expense and need for separate equipment have limited the practical use of synchrophasors in utility operations, a problem solved by SEL technology."

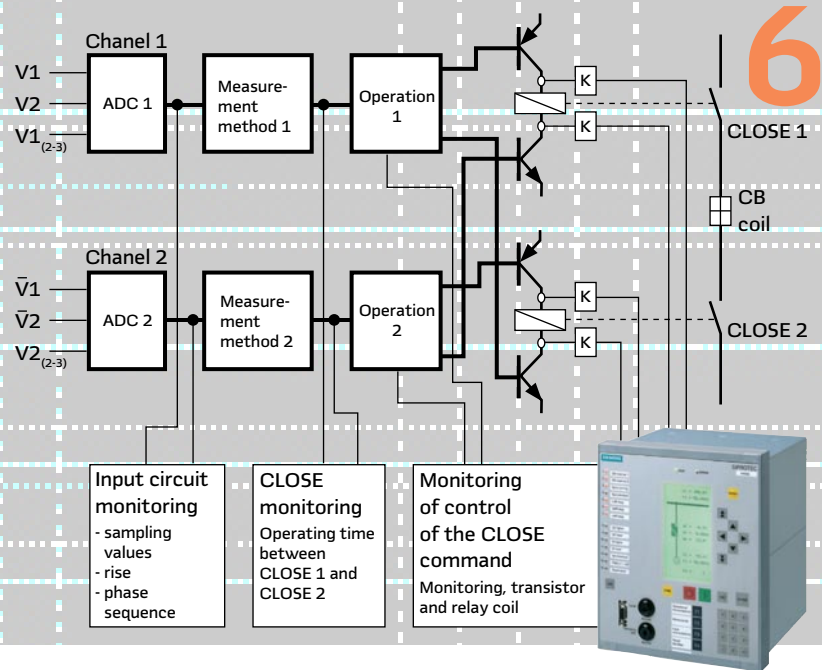

6

New paralleling device for applications requiring high reliability

The new Siemens SIPROTEC 7VE63 paralleling device is a multifunction relay used for paralleling large generators or power systems, which require high reliability. Its unique 2-channel measurement method and hardware design guarantees secure paralleling. Two independent measurement methods, algorithms and trip circuits must all concur to allow secure operation. The unit has superior control and monitor functions, as do all the SIPROTEC 4 relay family. Voltage and frequency functions ($V>$, $V<$, $f>$, $f<$, df/dt) are available for Generator protection or network decoupling applications.

7 Full IEC 61850 compliance in substation automation

The Station Automation Series COM 600 provides superior interoperability and data exchange between industrial or utility IEDs and local or higher level systems. The series consists of three products: COM 605 with a local or remote HMI, the COM 610 communications gateway for remote connectivity and the COM 615 substation computer combining local HMI and communication gateway functions in the same device. In addition to the IEC 61850 protocol COM 600 provides a wide set of standard communication protocols. COM 600 is built on industrial grade hardware.



8 New teleprotection terminal

The use of the most advanced technology together with DIMAT's wide experience in digital and analog teleprotection terminals have resulted in the new universal teleprotection terminal type TPU-1. The modular design of TPU-1 terminals allows the use of different types of modules according to the teleprotection needs of each application. This allows it to manage one or two digital and/or analog channels. In cases where it manages two channels, it can be configured to operate as two independent teleprotection terminals or one teleprotection with main and back-up channels. TPU-1 terminals allow the transmission of up to 4 commands over analog channels and up to 8 commands over digital channels. Additional features include Web Management, GPS time synchronization, back-up power supply module option, LCD screen for counters displaying, TPU-1 terminals are compatible with IEC 61850 standard and communicate with protection devices using GOOSE messages.

9 Novel Relay Protection Systems for Electric Arc Furnace Power Transformers

Cooper Power Systems developed advanced relay protection systems for electric arc furnace (EAF) power transformers that incorporate Rogowski coil (RC) current sensors and multifunction relays. In the past, differential protection schemes were not

applied on EAF transformers due to the difficulty in providing conventional iron-core current transformers (CTs) of sufficient rating for the conductors carrying currents of 60 kA or more. Rogowski coils are low power sensors, linear (do not saturate), accurate, and immune to

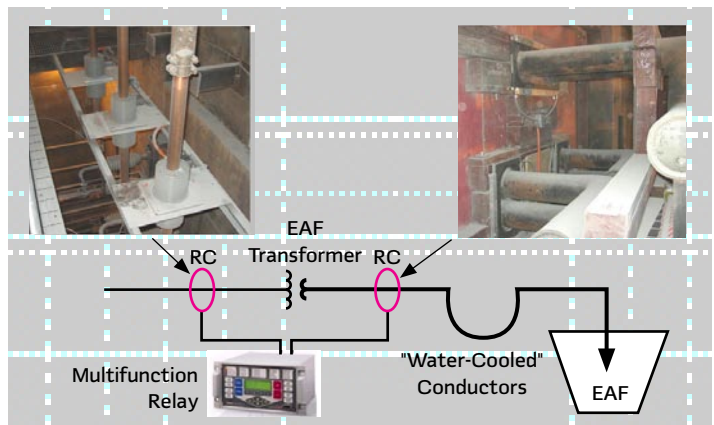

external electromagnetic fields. Rogowski coils may replace CTs in all metering and relaying applications, providing

superior relay protection schemes to protect power transformers, generators, lines, and busbars. Several EAF transformer

differential protection projects have been implemented. They have reliably operated since their installation (now over two years).