

2 Tough Ethernet Switch Operates in Extreme Conditions Without Losing Data

Schweitzer Engineering Laboratories, Inc. (SEL) is now shipping the SEL-2725 Five-Port Ethernet Switch, an unmanaged edge switch and media converter, Connect the wired Ethernet ports of four devices to an SEL-2725 using Category 5 shielded, twisted-pair cables. Safely link to a station Ethernet network with the fiber-optic port.

The SEL-2725 is a tough, reliable solution for a wide variety of applications, withstanding vibration, electrical surges, electrostatic discharge, fast transients, and extreme temperatures. It meets or exceeds IEEE 1613 (Class 2) standards for substation communications devices and drops no packets throughout this rigorous testing! The SEL-2725 is available now for \$450.



3 AREVA T&D opens North American Center of Excellence



In order to optimize the service level for its Protection and Substation Automation customers in North America, AREVA's Transmission and Distribution (T&D) Division has created a center of excellence at its existing site in La Prairie, Quebec. As of December 1st, 2007, Protection, Substation Automation and associated service activities, currently conducted out of AREVA's Bethlehem, PA facility in the U.S., are transferred to its Montreal site. All AREVA's Measurement Products (usually conducted under the BiTRONICS brand) will continue to be designed, manufactured, delivered and served from AREVA's factory in Bethlehem and are not affected by the transfer.

AREVA's North American Protection and Control Center of Excellence will act as the repair, maintenance and technical support center for the full installed base of Protection products and Substation Automation systems in North America. Damien Tholomier, Commercial Director of AREVA's North American Automation products said, *"We are constantly striving to provide quality, reliable and high-performance products and systems, along with outstanding service based on fast response critical to operations. The creation of this center of excellence in our existing site in La Prairie, Montreal is just another example of AREVA's dedication to its North American customers."*

4 Successful Site Trial of Toshiba's Ground-Breaking Relay

Toshiba's new line differential protection GRL150 has been successfully applied on a 33kV cable-feeder circuit with UK utility SP Power Systems. GRL150 is an advanced numerical relay which can act as a direct replacement for conventional analogue pilot-wire differential relays, connecting directly to the metallic

pilots via integral 5kV isolation without the need for external modems or other equipment. In addition to phase-segregated differential protection, GRL150 also provides signalling channel supervision, transfer trip, inrush restraint and back-up protection functions, and can also be applied over fibre



optic communication links. During the course of a 1 year trial, a number of primary system faults occurred (both internal and external to the protected zone), with GRL150 performing correctly in each case, its communication system proving highly robust under severe conditions in terms of channel noise.

5 GARD 8000 IEC 61850 Compliant System

The GARD 8000 Communications and Relaying System from RFL Electronics, Inc. includes an Ethernet communication module that provides a "bridge" for substation-to-substation communications in an IEC 61850 application. The communication media between the substations can be any of the media GARD 8000 supports; fiber,

T1/SONET (E1/SDH), audiotone or Power Line Carrier. Alternatively, the Ethernet communication module can be used for teleprotection signaling over an Ethernet network, using GOOSE messaging. Back-to-back operating time is 3 ms (typical) which makes it an attractive solution for any teleprotection needs over an Ethernet network.

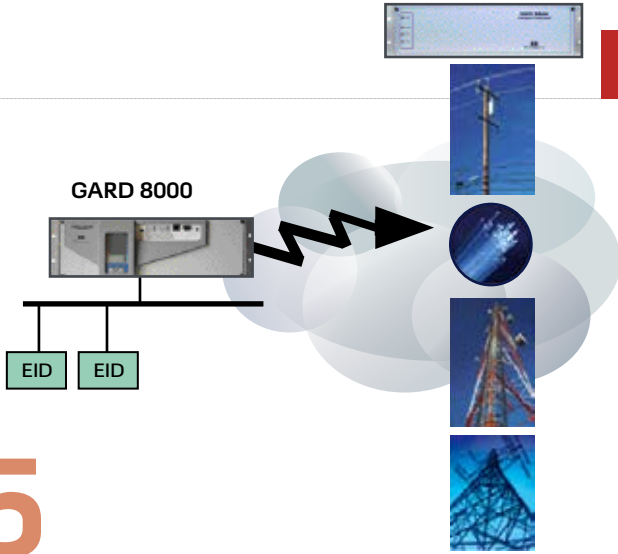

6 Powerful Dynamic Range Test Equipment

OMICRON electronics proudly introduces the CMC 356, uniquely designed for the modern requirements of protection & control testing and commissioning/maintaining substations. It exceeds expectations with powerful, wide dynamic range current sources (1mA resolution, 6x32A or 3x64A or 1x128A rms @ max 6x430VA). Unmatched versatility: test high-burden, electro-mechanical relays (or an entire panel of them), up to 12 additional low-level analog outputs, and optional: IRIG-B sync for End-to-End or PMU testing, IEC 61850 device testing, or EnerLvzr (analog measurement) with just one test set – it's a commissioning engineer's prayer.

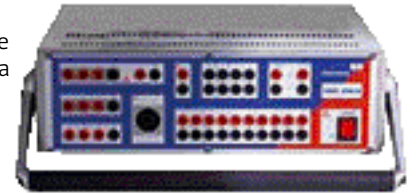

7 Wide Area Coordination Study of Protection Coordination in the Transmission System and Boundaries

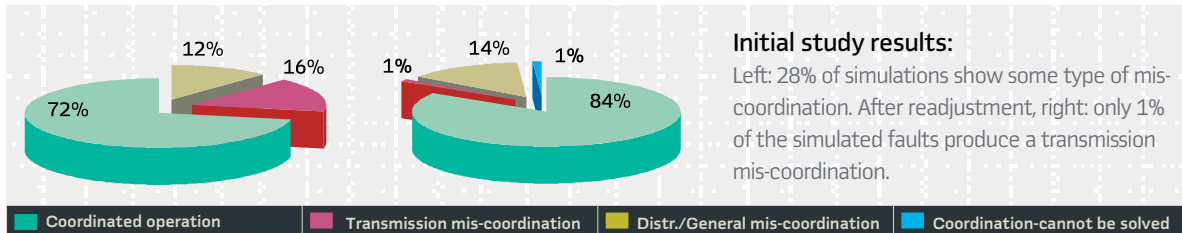

Initial study results:

Left: 28% of simulations show some type of mis-coordination. After readjustment, right: only 1% of the simulated faults produce a transmission mis-coordination.

Detecting a lack of coordination before relay misoperations occur reduces risk of interruptions in service, brownouts, and blackouts. Automated Wide Area Coordination reviews are a practical way to increase system reliability.

In 2006, Rede Eléctrica de España (in Madrid) conducted a wide area review of protection coordination in a large portion of their transmission network, including the boundaries between generation, transmission, and distribution. Their study used an

automated application of Electrocon International's CAPE software, uncovering hidden miscoordinations and other protection problems.

You can request the 2007 WPRC technical paper: eii@electrocon.com or www.electrocon.com

you can't miss it

8

Non-Operational Data Access

Accessing breaker wear, fault records and oscillography from relays is now easier through the use of a set of software tools for the Orion Automation Platform. NovaTech's Orion Software Suite includes tools to:

- Access relays remotely, through Orion
- Make Breaker Wear, History and Short Event Summaries available to SCADA
- Automatically retrieve, parse and disseminate Full-Length Event Report to enterprise PCs
- Display relay data on pre-formatted web pages served from Orion.

Traditional automation function, such as accessing SCADA data, retrieving time stamps and sending down IIRIG-B, are also supported in the Software Suite.

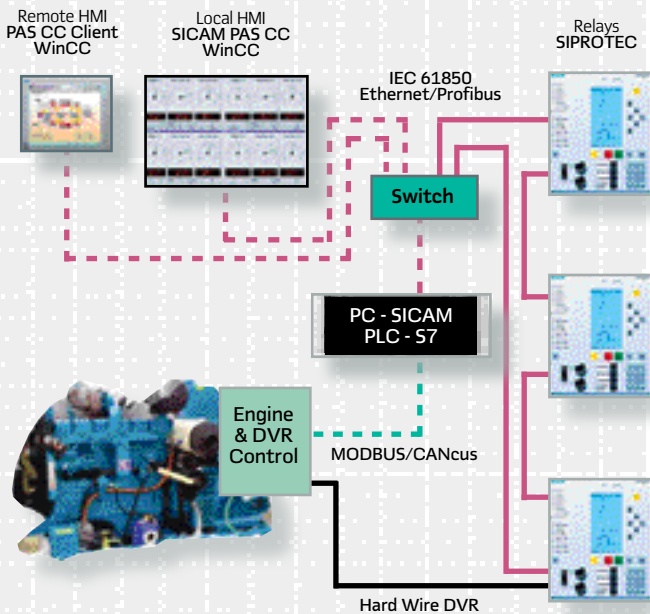
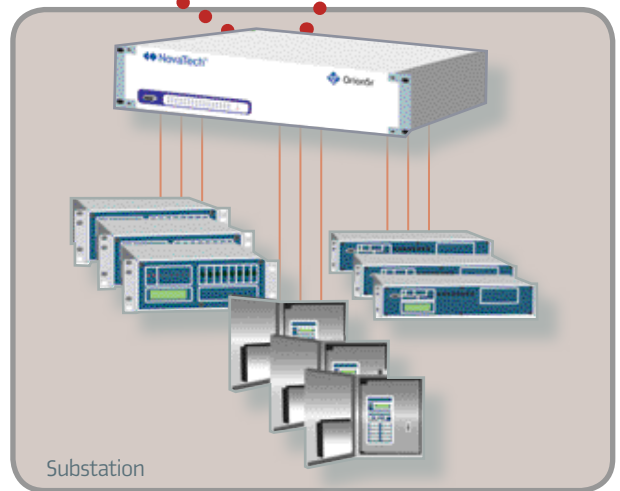

9 Generator Protection Control

9

The **SICAM & SIPROTEC** Generator Protection, Control & Monitoring System is a complete ready to install solution for local plant power generation and distribution systems. The system is suitable for integration into most generator manufacturer's digital engine and voltage controls. It can be extended into other distribution switchgear lineups to provide

complete automated logic control and interlocking for entire distribution systems. The settings of the relays are included and all functionality is tested and proven prior to delivery. Generators can be securely paralleled using the 7VE6 Relay synchronization algorithms. An HMI provides clear local or remote control & monitoring. The system architecture is designed to digitize

all pieces of primary gear. This information is then shared on a common IEC61850 bus with peer to peer "GOOSE" messaging. Unlike standard solutions available in the market, this system does not require any additional control hardware for generator paralleling. This system is complete protection control and generator paralleling solution using SIPROTEC relays and a PC or PLC.

