

Reducing the Effects of Short Circuit Faults on Sensitive Loads in Distribution Systems

Alexander Apostolov
AREVA T&D Automation

I. INTRODUCTION

The electric utilities industry is going through significant changes related to the reduced tolerance of major customers to deviations from the nominal parameters of electric power. Most of the power quality events that result in failure of different types of equipment involved in a manufacturing or other processes are caused by short circuit faults. Microprocessor based multifunctional Intelligent Electronic Devices (IED) are becoming the standard protection, control, monitoring and recording equipment in new or existing substations. They provide increased capabilities to detect short circuit or other abnormal conditions and reduce the total fault clearing time, thus reducing the effect of the fault on sensitive equipment.

The sensitivity of many industrial facilities to variations in system parameters [1] results in increased requirements for improved quality of power supplied by the utility. A new approach to distribution protection will help avoid costly interruptions of manufacturing or other processes when a short circuit fault occurs in the distribution system.

The paper discusses the effects of different short circuit faults on the voltage profile across the distribution system. The behavior of typical distribution feeder protection or substation protection systems is analyzed from the perspective of the definitions of voltage related power quality events.

Multifunctional protective IEDs are then considered and it is demonstrated that by using all available advanced distribution protection schemes and programmable logic functions the user can reduce the effect of short circuit faults on sensitive loads supplied from the distribution substation. Combination of instantaneous, definite time and inverse time-delayed phase, ground and negative sequence elements will result in significant reduction in the duration of the fault. This will lead to changes in the voltage level/time characteristics of the fault condition and reduced probability for the costly interruption of voltage sensitive processes.

II. VOLTAGE VARIATION POWER QUALITY EVENTS

The most common power quality events that affect sensitive customers and may result in shut down of manufacturing process and significant losses are in the group of voltage variations. The definitions of such events vary in the details, but essentially they are not very far from the ones from the IEC standards.

A voltage dip is a temporary reduction of the voltage at a point in the electrical system below a threshold. Dips (or sags in North America) are classified as events by the duration and voltage level.

Alexander P. Apostolov is with AREVA T&D Automation, Los Angeles, CA 90064, USA (e-mail: alexander.apostolov@areva-td.com).

If the voltage drops below a very low threshold, the voltage dip becomes a voltage interruption.

A voltage swell is a temporary increase of the voltage at a point in the electrical system above a threshold .

In all of the above cases the thresholds specify the voltage magnitude for the purpose of detecting the start and the end of a voltage variation event. They are then used to determine the duration of the power quality event.

Another voltage variation event is voltage unbalance, defined as a condition in a polyphase system in which the r.m.s. values of the line voltages (fundamental component), or the phase angles between consecutive line voltages, are not all equal. The degree of the inequality is usually expressed as the ratios of the negative and zero sequence components to the positive sequence component .

There are many other power quality events, such as transients, frequency or power factor variations, flicker. However, since they are not significantly affected by the performance of the distribution system protection devices, we will consider them out of scope of this paper.

Instead, we will concentrate on the voltage variation events and analyze how optimizing the protection of the distribution results in reduction of the severity of these events and their effect on sensitive users.

III. EFFECTS OF SHORT CIRCUIT FAULTS

The improvement of power quality during short circuit faults can be achieved in several different ways. Like any other problem that has to be solved, we need first to understand the nature of the problem and it's effect on sensitive users. The most common short circuit faults in the system – single-phase to ground faults – are characterized by the fact that they introduce a voltage sag in the faulted phase, and at the same time they result in a voltage swell in the two healthy phases. This is clearly seen in Figure 1 that shows the recorded waveform and the voltage phasor diagram for a single-phase to ground fault.

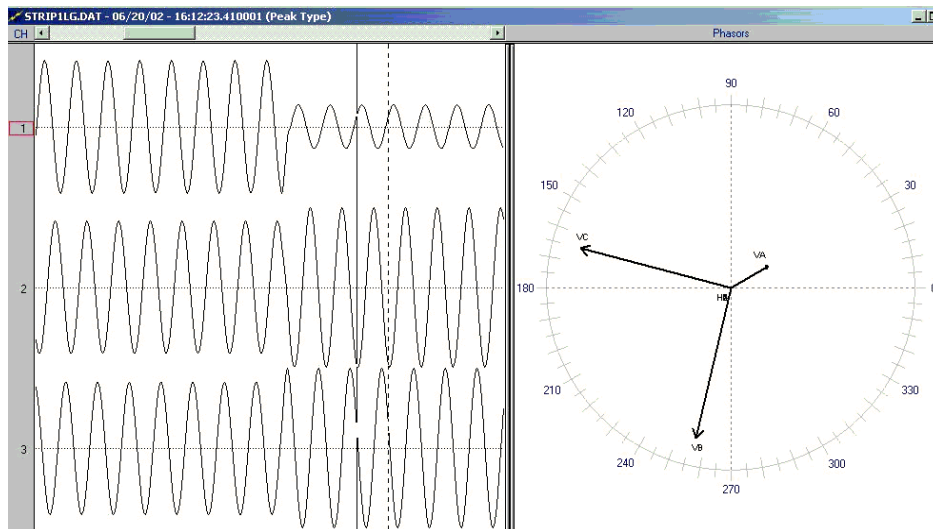

Figure 1 Phase voltages for a single-phase-to-ground fault (Phase A)

The case of two or three-phase faults is quite different. For three-phase faults all phases experience a voltage sag, while for a two-phase fault - the two faulted phases will have lower voltages, with the healthy phase without a significant change compared to the pre-fault levels.

Another factor to be considered in the analysis of short circuit faults is the automatic reclosing. The difference there is that when the fault is on the transmission system or on a distribution feeder, all loads are exposed to voltage sag during the duration of the fault.

As soon as the fault is cleared, all loads, except the ones connected to the faulted circuit, will have their voltage go back to normal. At the same time during the reclosing interval the loads connected to the faulted line will experience a voltage interruption.

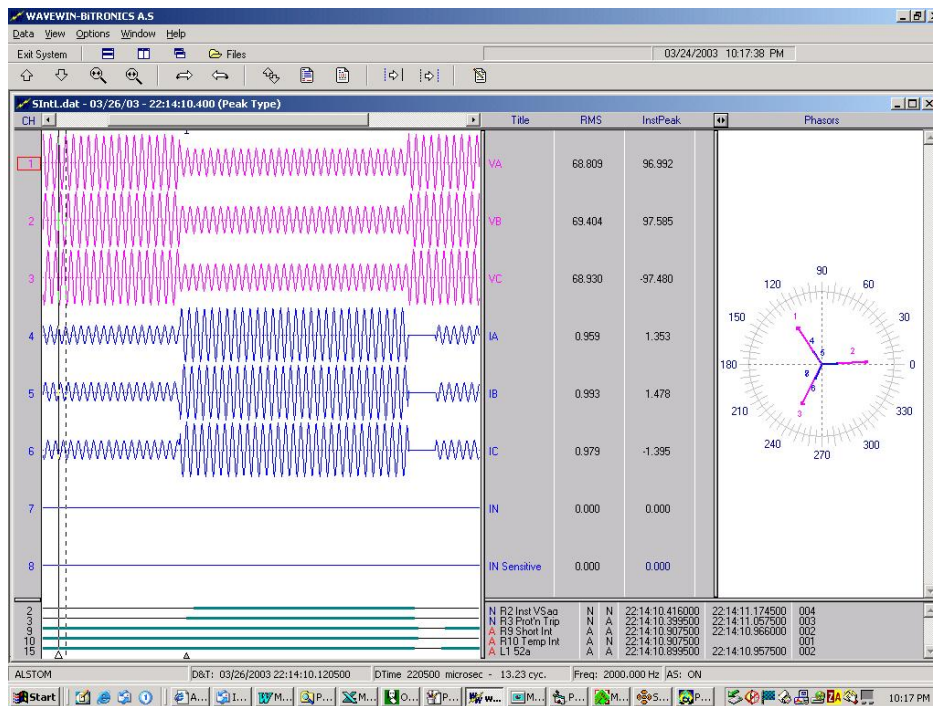

Fig. 2 Voltage waveforms for a three phase fault with successful reclosing

Figure 2 shows the recorded voltage waveforms on a faulted distribution feeder for a three-phase fault with a one-shot successful reclosing

The effects of voltage sags and swells on sensitive equipment have been studied for many years by industry organizations such as the Computer and Business Equipment Manufacturers' Association (CBEMA). They record both characteristics of this power quality event – the depth of the sag and its duration. The ITI (CBEMA) Curve (Figure 3), is published by Technical Committee 3 (TC3) of the Information Technology Industry Council (ITI, formerly known as the Computer & Business Equipment Manufacturers Association) [1]. It shows in a graphical format an AC input voltage envelope which typically can be tolerated (no interruption in function) by most Information Technology Equipment (ITE).

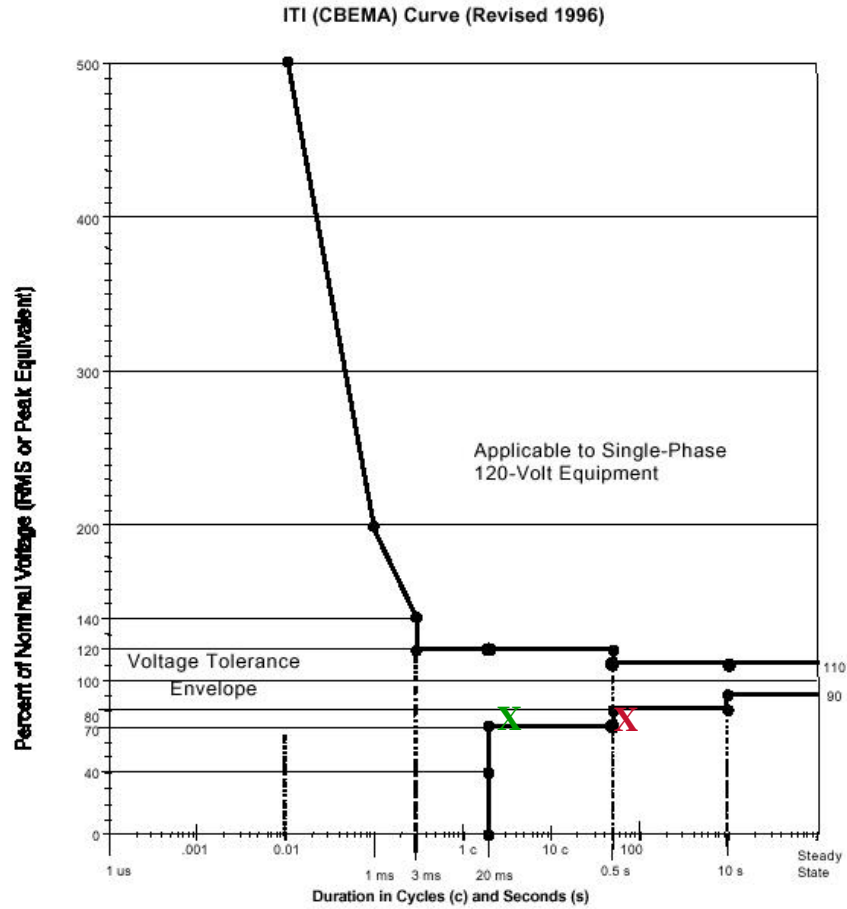

Fig. 3 ITI (CBEMA) curve

Fig. 4 shows a plot of depth vs. duration of actual cases from a high-volume manufacturing plant [2], with some of them resulting in process shutdown due to variable speed drives and vacuum pumps failures.

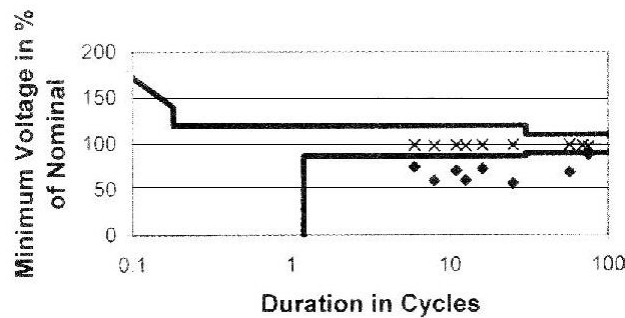

Fig. 4 ITI (CBEMA) curve from a manufacturing plant

There are several factors that determine the voltage level during a short circuit fault on the transmission or distribution system:

- System configuration
- Fault location
- Fault resistance

Figure 5 shows the effect of the fault resistance (in ohms) on the voltage at the substation, for faults at the end of a sub-transmission line.

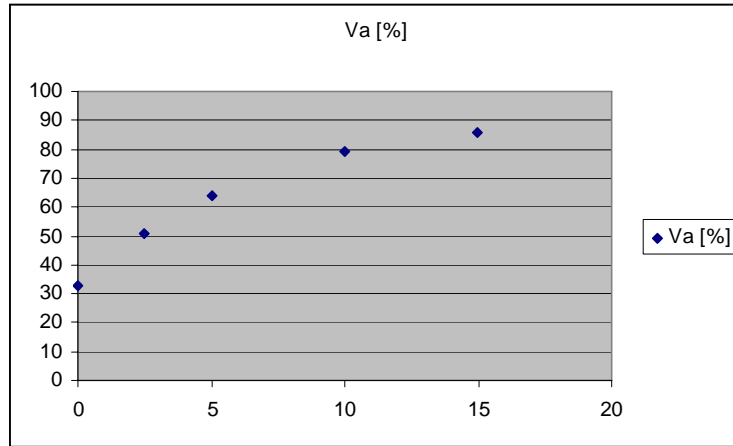

Fig. 5 Effect of fault resistance on voltage drop

The first characteristic of a voltage sag – the depth – is something that we can't control, but we have to study in order to be able to predict or estimate the effects of different faults on the sensitive equipment.

The second characteristic of the voltage sag – the duration – is the parameter that we can control by properly applying the advanced features of state-of-the-art multifunctional distribution feeder protection relays.

IV. OPTIMIZING DISTRIBUTION PROTECTION

The duration of the voltage sag is a function of the distribution feeder protection relay operating time and the breaker opening time:

$$t_{VSag} = f(t_{Prot}, t_{Bkr}) = t_{Prot} + t_{Bkr} \quad (1)$$

where:

t_{VSag} - the duration of the voltage sag

t_{Prot} - the operating time of the feeder protection

t_{Bkr} - the breaker trip time

In an optimization problem we seek values of the variables that lead to an optimal value of the function that is to be optimized. Based on this definition, we can present our optimization problem as:

To minimize the duration of voltage sags for different types of faults, fault locations and system configurations.

Since replacing distribution feeder breakers in order to find the optimal solution is very expensive and might be difficult to justify, we can assume that for specific distribution feeder the breaker trip time is fixed within a range around the breaker nominal trip time. We can thus assume that

$$t_{Bkr} = \text{const} \quad (2)$$

The breaker trip time at the distribution level is typically 5 cycles, i.e. 80 msec at 60 Hz or 100 msec at 50 Hz.

The optimal solution will be

$$\min\{ t_{VSag} \} = \min\{ t_{Prot} \} + t_{Bkr} \quad (3)$$

Typical distribution feeder protection is based on phase and ground overcurrent relays set to protect the line for three-phase, phase-to-phase or phase-to-ground faults. An instantaneous relay is used to operate for close-in faults and a time overcurrent relay with inverse characteristic provides protection for most faults on the line. The time overcurrent relay has to coordinate with any fuses used to protect distribution transformers connected to the feeder. The coordination requirements for high current faults result in significant increase in the operating times for faults further down the line, with the longest times for faults at the remote end.

In order to reduce the number of electromechanical or solid state relays, backup protection for bus faults or breaker failure has been traditionally provided by the transformer protection relays. Considering the fact that they also have to coordinate with the feeder relays, it is obvious that the operating times for bus faults or feeder faults with breaker failure will not meet the requirements of sensitive customers.

State-of-the-art multifunctional protection relays have many features that allow significant improvements in the performance of the relays under different short circuit fault conditions. Properly configuring and setting the relays will allow the user to find the optimal solution defined in (3).

We are going to analyze different methods that allow us to reduce the distribution feeder protection operating time.

A. Definite Time Versus Inverse Time Overcurrent

Modern distribution feeder protection relays have multiple phase and ground overcurrent elements that can be used to reduce the operating time of the relay for different fault conditions.

Figure 6 shows the inverse time characteristic of a phase overcurrent relay with the operating points for different fault locations on the protected feeder. The characteristic is coordinated with a downstream fuse.

If a relay with four phase overcurrent elements is used to protect the distribution feeder, it can be set with one instantaneous, two definite time delayed and one inverse time overcurrent characteristic.

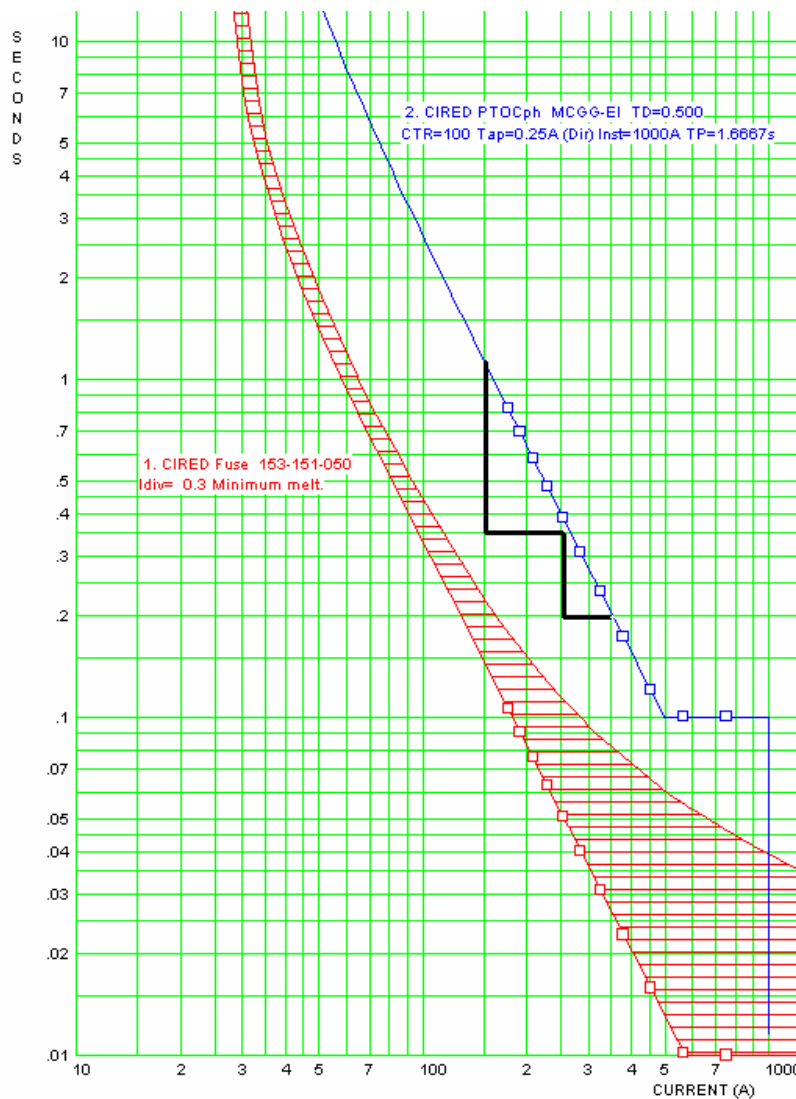

Fig. 6 Inverse versus Definite Time Overcurrent

The two definite time delayed elements are shown with bold lines in Fig. 6, thus giving the overall time characteristic. Table 1 shows a comparison of the operating times of the traditional inverse time characteristic compared with the use of the two additional definite time delayed

overcurrent elements with settings of 0.2 s and 0.35 s.

The last column in the table gives the difference in the operating times. The advantages are quite significant, especially for the faults closer to the end of the line.

TABLE 1 – Operating Time Comparison

Fault location	TOC time	DTOC time	Δ time
40 %	0.24 s	0.20 s	0.04 s
50 %	0.31 s	0.20 s	0.11 s
60 %	0.39 s	0.35 s	0.04 s
70 %	0.48 s	0.35 s	0.13 s
80 %	0.59 s	0.35 s	0.24 s
90 %	0.70 s	0.35 s	0.35 s
100 %	0.82 s	0.35 s	0.47 s

B. Negative Sequence Overcurrent Protection

When applying traditional phase overcurrent protection, the overcurrent elements must be set higher than maximum load current. This limits the sensitivity of the phase relays and also results in increased operating times for line end faults. Since the levels of the phase fault currents for phase-to-phase faults are lower than the levels for three-phase faults, this will lead to further increase in the time required to clear the fault.

If we consider an example for a phase-to-phase fault at 75 % of the protected feeder, the voltage at the relay location is 0.79 Unom and the phase overcurrent relay with inverse characteristic used for Table 1 and Fig. 6 will operate in 0.71 s. For the same three-phase fault the voltage drop seen by the relay is to 0.71 Unom with operating time of 0.53 s.

Any unbalanced fault condition will produce negative sequence current of some magnitude. Thus, a negative phase sequence overcurrent element can operate for both phase-to-phase and phase-to-ground faults. If a definite time negative sequence overcurrent element is used, it may be set to clear the same phase-to-phase fault in less than 0.3 s. This will bring the duration of the fault within the acceptable region of No Interruption in Function.

Negative phase sequence overcurrent elements also give greater sensitivity to resistive phase-to-phase faults or high resistance phase-to-phase-to-ground faults, where phase overcurrent elements may not operate at all.

C. Distribution Bus Protection.

The selection of protection equipment for bus faults until recently was based on the requirements for stability of the power system. Because of that the protection of buses in the case of short circuit faults at the transmission level is usually provided by high or low impedance bus differential relays. Since they require the installation and maintenance of additional equipment, in most cases the distribution bus protection has been done by the backup time delayed overcurrent protection of the transformers.

The increased understanding of the effects of longer fault clearing times on sensitive industrial equipment results in a change in the philosophy on distribution bus protection. In many cases it is now based on the exchange of signals between the feeder relays and the transformer protection relays in order to provide faster clearing of bus faults.

The implementation of this form of distribution bus protection is possible only when there is a single source, i.e. there is no source at the remote end of any of the distribution feeders.

All overcurrent starting signals from the multiple feeder relays are paralleled and used to energize an opto-input of the transformer overcurrent protection relay.

For a fault on any of the distribution feeders the relay protecting the faulted feeder will start and with or without time delay (depending on the fault location) will issue a Trip signal to clear the fault.

Figure 7 shows a simplified block diagram of a distribution bus protection. If the fault is on one of the feeders, the protective relay of that feeder will immediately operate an output that is wired to an input of the transformer relay. This signal will indicate a feeder fault and will block the operation of the bus protection function.

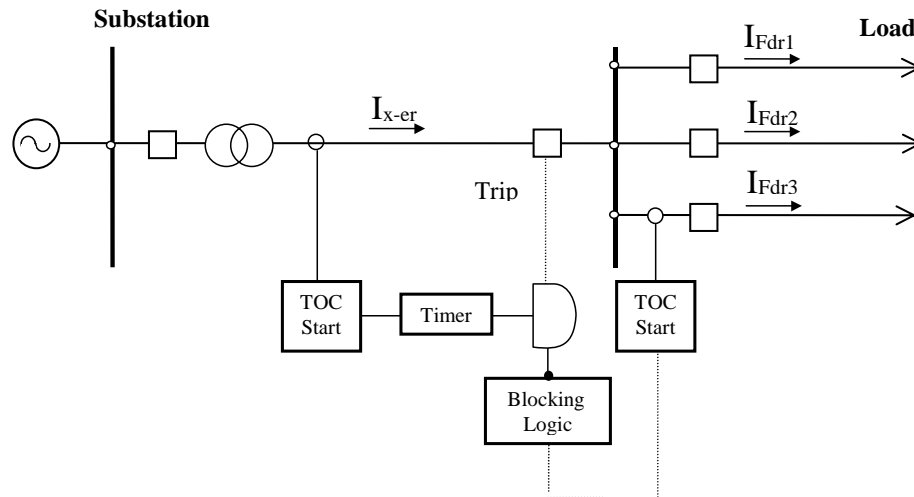

Fig. 7 Simplified distribution bus protection diagram

If the fault is on the bus, no feeder relay will operate, thus indicating to the transformer protection relay that it is a bus fault. The overcurrent elements that are used to implement a

distribution bus protection scheme have to be set with a certain time delay that allows the receiving of a signal from any of the feeder relays. At the same time each feeder relay should be able to communicate the starting of an overcurrent element that is used to block the bus protection element.

The advantage of this type of scheme therefore is that it allows fast fault clearing of distribution bus faults without the need for installation of a distribution bus differential protection.

D. Breaker Failure Protection

The requirements for improvements in the quality of power supplied to electric utility customers result in changes of the way distribution feeder protection is designed and applied. Many protection schemes that in the past have only been used at the transmission level today are common at the distribution level. One of these schemes is the Breaker Failure Protection.

One of the most severe fault conditions in the electric distribution system is the failure of the breaker to trip in case of a fault detected by the protective relays. This results in prolonged exposure of the industrial customers to low voltages and of electrical equipment to large short circuit currents and may lead to damage of equipment and complete shut down of the manufacturing process. This is the reason that Breaker Failure Protection has gained popularity at the distribution level of the system.

The most common Breaker Failure Protection is based on monitoring of the current in the protected circuit. After a fault is detected and the relay issues a trip signal, it will also initiate the timer of the Breaker Failure Protection function. If the breaker trips as expected, the current in all three phases will go to zero, which will reset the undercurrent element used to detect the correct breaker operation.

Since at the distribution level the feeder is protected by a single relay, the Breaker Failure Protection function is usually started by a built-in protection function in the distribution feeder protection relay.

E. Fuse Saving Scheme

Distribution feeders are used to supply power to multiple customers through distribution transformers, typically protected by fuses. The reason is that this is an inexpensive way of protecting the transformers. Since short circuit faults do not occur very often, it is widely implemented.

The problem with fuse protection is that it does not allow automatic restoration of the power supply and also requires a crew to be sent to the location and replace the fuse. This can lead to a significantly long supply interruption. Considering the fact that most short circuit faults have a temporary nature, attempting to clear the fault before the fuse burns has become a standard practice in many utilities.

This is achieved by applying a Fuse Saving Scheme. The idea is to use a low set instantaneous overcurrent element to trip the breaker in the substation immediately after the fault occurs. In this case there is no coordination of the instantaneous overcurrent element with the downstream fuses. The breaker is tripped before the fuse protecting the faulted section (or a distribution transformer) will start to melt. After the reclosing the low set instantaneous element is disabled and a high set instantaneous, as well as a time-overcurrent element that both coordinate with the

downstream protective devices are used.

The advantage is that in case of a temporary fault the fuse is not going to melt, i.e. it will not require a replacement and will result in a short interruption of the load during the dead interval of the reclosing sequence. This can be very important, especially in cases where the fuse is at a remote location, and under difficult meteorological conditions, when it will take a long time for the crew to get to the location and replace the fuse.

The disadvantage is that all the customers supplied from the feeder will be affected by the interruption during the reclosing cycle. The power quality events in this case are a voltage sag caused by the short circuit, followed by a short interruption during the reclosing dead time. That is why the decision to apply the Fuse Saving Scheme should be made based on the sensitivity of the load connected to the feeder to voltage sags or voltage interruptions.

F. Selective Backup Tripping

Protection of distribution feeders today is commonly provided by a single multifunctional relay. If the relay fails while there is a fault, the protection is typically provided by time-delayed overcurrent elements of the transformer protection that trips the transformer breaker. This has the negative result of first delayed operation and second the tripping of the source breaker leading to a voltage interruption of all feeders connected to the distribution bus.

A significant improvement can be achieved by the selective backup tripping from the transformer relay. If it receives a signal that the feeder relay has failed, when a fault is detected and there is no blocking signal from any of the healthy feeder relays, the transformer relay will first send a trip signal to the breaker of the feeder with the failed relay. If the fault is on that feeder, it will be cleared, thus eliminating the need for tripping the transformer breaker and causing the voltage interruption for all feeders.

V. CONCLUSIONS

Modern multifunctional protection and monitoring or recording IEDs allow the optimization of the protection and controls schemes that lead to significant reduction in the duration of voltage sags or swells.

Combining an inverse-time overcurrent protection element with definite time delayed and instantaneous elements results in an overall characteristic that optimizes the overcurrent function of the relay.

Use of negative sequence overcurrent elements for faster detection of phase-to-phase faults further improves the performance of a distribution feeder relay.

Advanced distribution protection logic schemes also reduce the fault clearing time. Such schemes discussed in the paper are:

- Distribution bus protection scheme
- Fuse saving
- Breaker failure protection
- Selective backup tripping

While different recording modes result in better understanding of power quality events and allow verification of the models used for different fault analysis studies, the application of advanced protection functions and adaptive protection reduces the length of voltage sags to an acceptable level.

VI. REFERENCES

1. ITI (CBEMA) Curve Application Note, <http://www.itic.org/technical/iticurv.pdf>
2. Sabbah S., 2002. "Power Quality and High Volume Manufacturing Plant", Power Quality 2002 Conference, Rosemont, IL, USA

VII. BIOGRAPHY



Alexander Apostolov received MS degree in Electrical Engineering, MS in Applied Mathematics and Ph.D. from the Technical University in Sofia, Bulgaria. He has worked for fourteen years in the Protection & Control Section of Energoproject Research and Design Institute, Sofia, Bulgaria.

From 1990-94 he was Lead Engineer in the Protection Engineering Group, New York State Electric & Gas where he worked on the protection of the six-phase line, application of microprocessor relays, programmable logic and artificial intelligence in protection. 1994-95 he was Manager of Relay Applications Engineering at Rochester - Integrated Systems Division. 1995-96 he was Principal Engineer at Tasnet.

He is presently Principal Engineer for AREVA T&D Automation in Los Angeles, CA. He is a Senior Member of IEEE and Member of the Power Systems Relaying Committee and Substations C0 Subcommittee. He is Vice-Chairman of the Relay Communications Subcommittee, serves on several IEEE PES Working Groups and is Chairman of Working Group C9: Guide for Abnormal Frequency Load Shedding and Restoration.

He is member of IEC TC57 Working Groups 10 and 17, and CIGRE WG B5.01 and Convener of B5.TF07. He is Chairman of the Technical Publications Subcommittee of the UCA International Users Group. He holds three patents and has authored and presented more than 150 technical papers.